

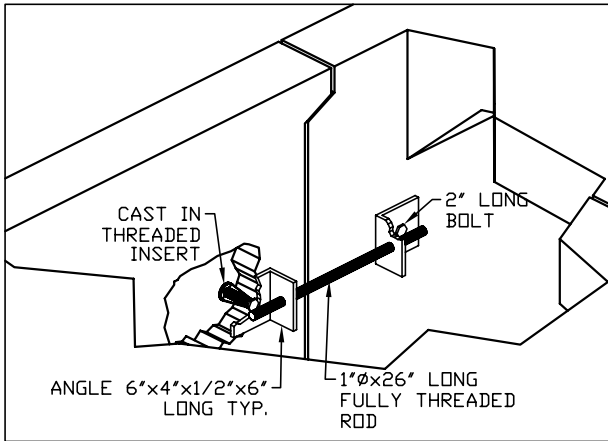

Concrete Systems Inc.  
 9 Commercial St., Hudson, NH, 03051  
 Phone 603-889-4163  
 Fax 603-889-0039

# Precast Box Culvert Single Cell



CLOSURE HARDWARE  
 DETAIL

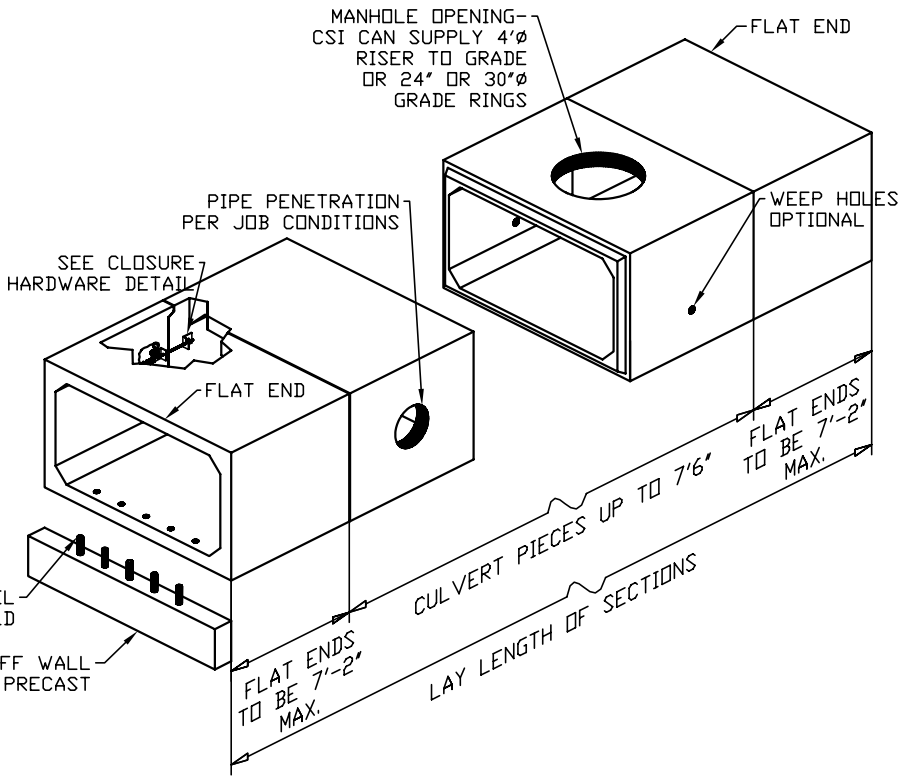

DRILL & DOWEL  
 IN FIELD

CUT-OFF WALL  
 C.I.P. OR PRECAST

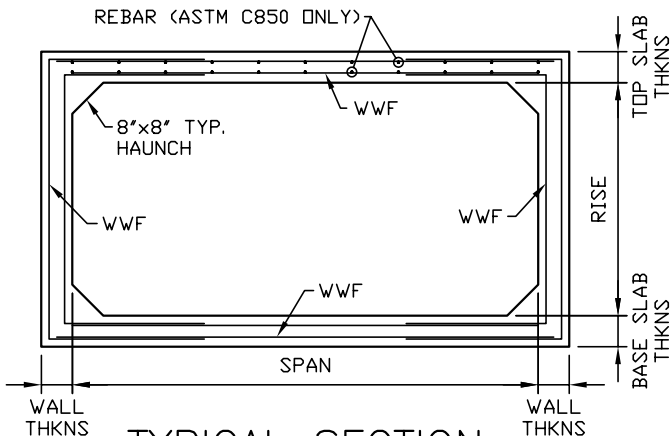

TYPICAL SECTION

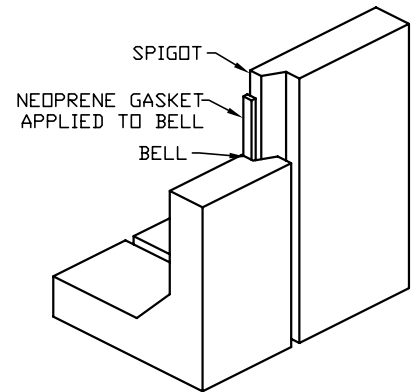

JOINT DETAIL

**GENERAL NOTES:**

- Structure designed and built in accordance with ACI 318-99 "Building Code Requirements for Structural Concrete" and ASTM C789 or C850. Other design codes: AASHTO, AREA, FAA Airport Loading & BOCA as required.
- Design Parameters:  
 Live load: As specified  
 Earth Cover: Per job condition  
 Concrete: Design strength  $f'c = 5000$  psi  
 Unit weight = 150 pcf  
 Reinforcing: ASTM A615 (Rebar) Grade 60  
 ASTM A185 (Welded Wire Fabric) Grade 70
- Exterior dampproofing can be supplied by CSI.