

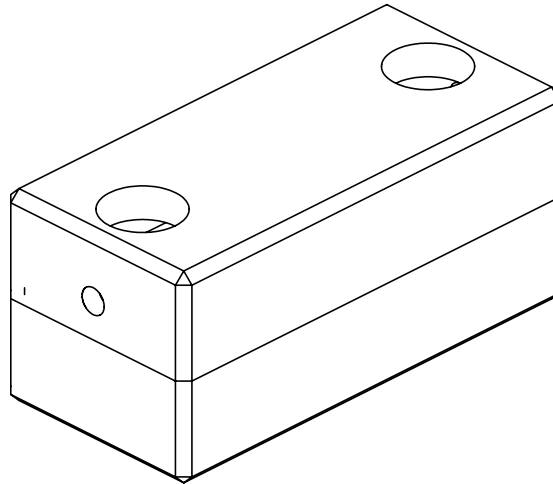

Concrete Systems Inc.
 9 Commercial St., Hudson, NH, 03051
 Phone 603-889-4163
 Fax 603-889-0039

2,500 Gallon Heavy Duty Tank Low Profile

Model# HT2.5KL



WEIGHT	
Top Section	Bottom Section
8.79	7.74
Total Weight	
16.53 Tons	

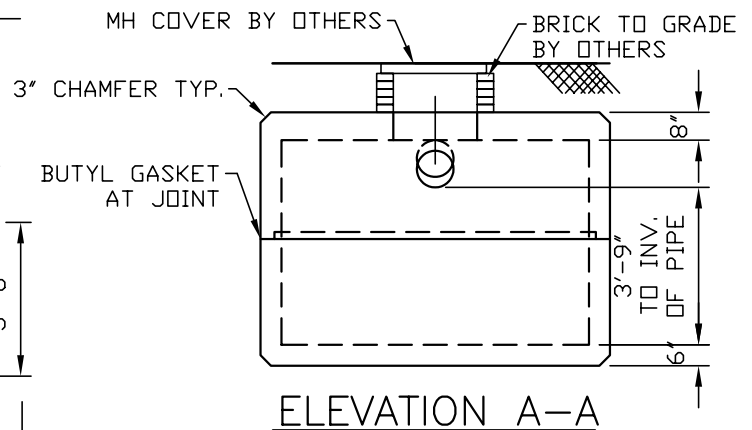
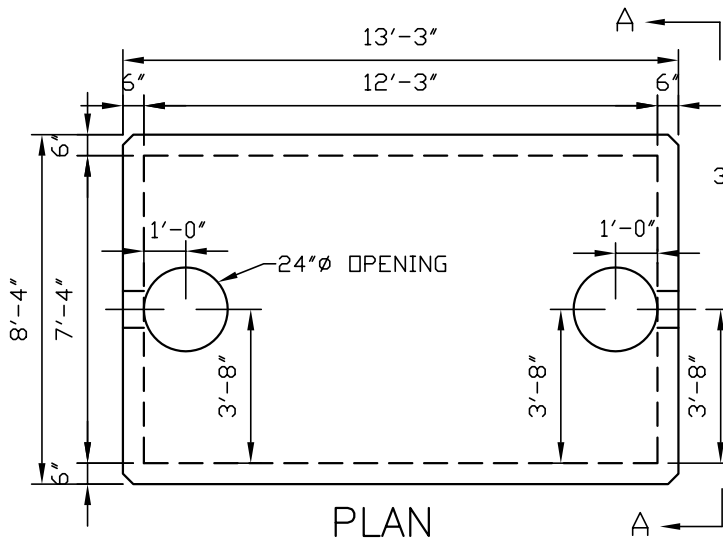

Design Parameters:

- Live load: HS20
- Earth Cover: 0 to 4'
- Concrete: Design strength $f_c = 5000$ psi
- Reinforcing: ASTM A615 (Rebar) Grade 60
 ASTM A185 (WWF) $f_y = 60,000$ psi