

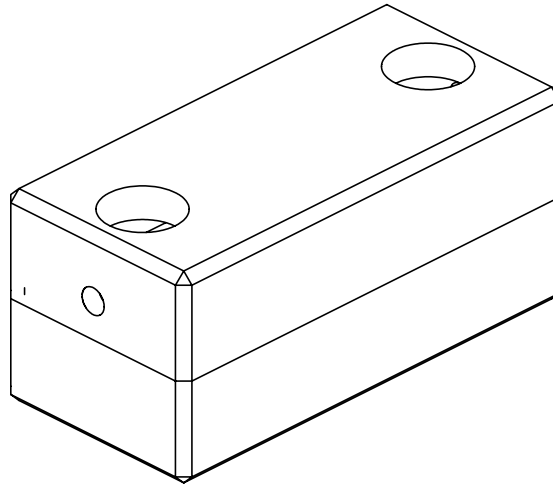

Concrete Systems Inc.  
 9 Commercial St., Hudson, NH, 03051  
 Phone 603-889-4163  
 Fax 603-889-0039

# 4,500 Gallon Heavy Duty Tank

Model# HT4.5K



WEIGHT	
Top Section	Bottom Section
11.11	10.06
<b>Total Weight</b>	
21.16 Tons	

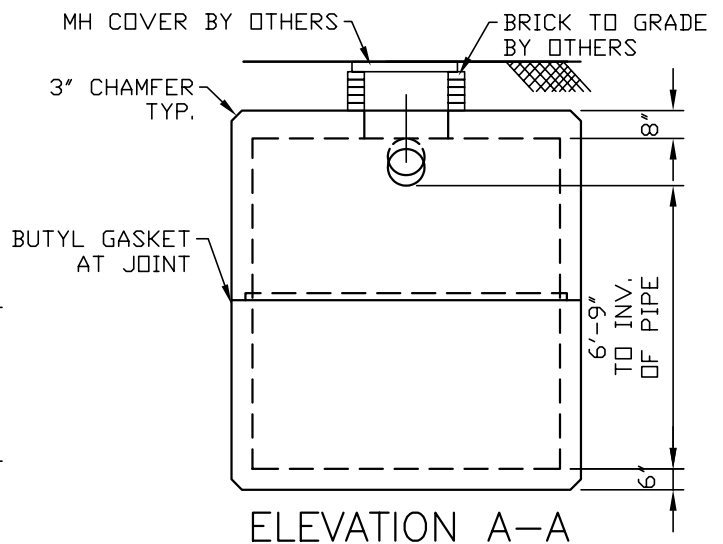
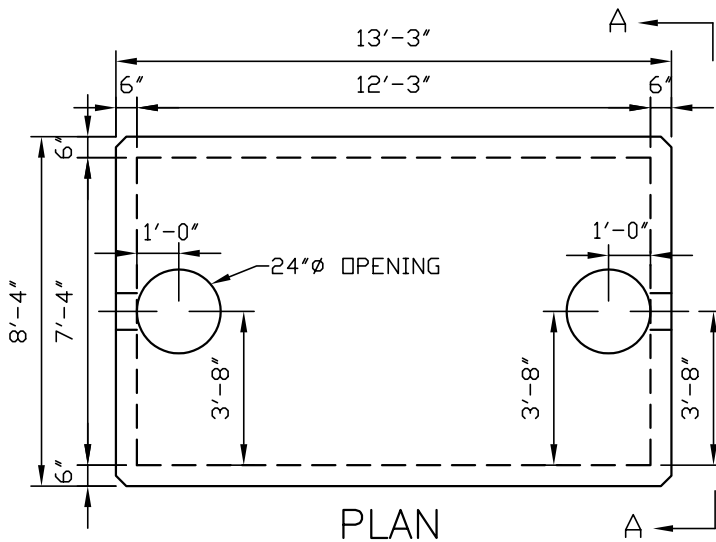

**Design Parameters:**

- Live load: HS20
- Earth Cover: 0 to 4'
- Concrete: Design strength  $f_c = 5000$  psi
- Reinforcing: ASTM A615 (Rebar) Grade 60
- ASTM A185 (WWF)  $f_y = 60,000$  psi