

REQUIRED INFORMATION FROM CONTRACTOR

STRUCTURE QUANTITY	INLET PIPE SIZE & TYPE	OUTLET PIPE SIZE & TYPE	ACCESS OPENING SIZE	BAFFLE WALL QUANTITY

TANK DIMENSIONS:
 INSIDE LENGTH = 16'-8"
 INSIDE WIDTH = 7'-4"
 OUTSIDE LENGTH = 17'-8"
 OUTSIDE WIDTH = 8'-4"

NOTE: CONTRACTOR TO SKETCH IN LOCATIONS OF INLET AND OUTLET PIPES AS WELL AS LOCATIONS OF ACCESS OPENINGS

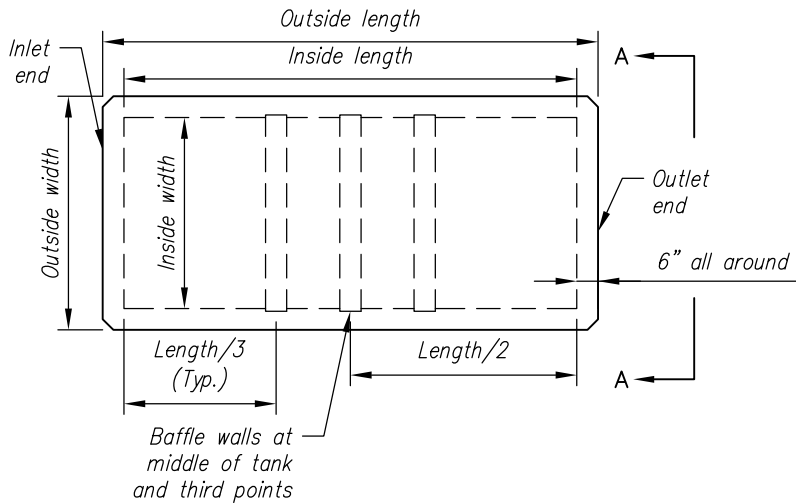

PLAN

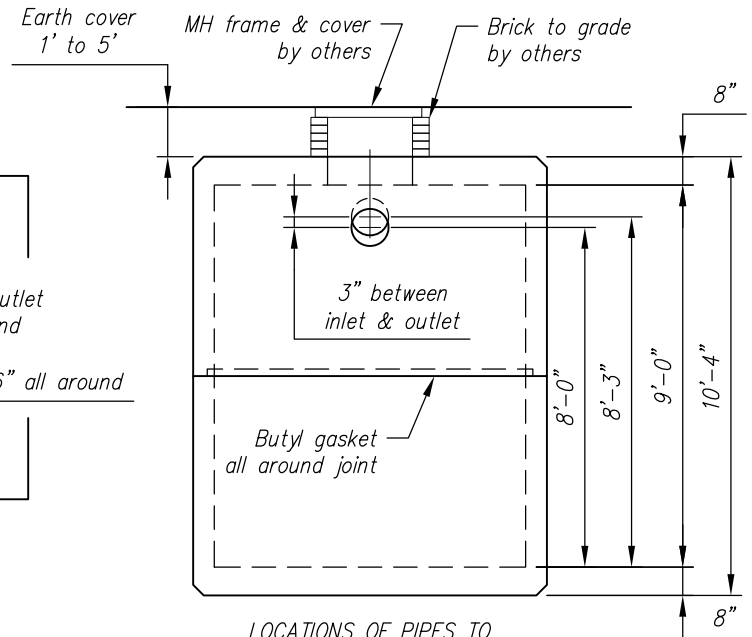

LOCATIONS OF PIPES TO BE PROVIDED BY CONTRACTOR

ELEVATION A-A

WEIGHTS (MAX.)		
UPPER SECTION	15.80	TONS
LOWER SECTION	15.80	TONS
BAFFLE WALL (EACH)	1.65	TONS

Design Parameters:

Live Load: AASHTO HS20-44
 Earth Cover: 1' to 5'
 Concrete: Design strength $f'_c = 5000$ psi
 Unit weight = 150 pcf
 Reinforcing: ASTM A615 Grade 60
 Earth Pressure Coefficient = 0.30
 Soil: Unit weight = 120 pcf
 Cover to reinforcing: 1 1/2" u.n.o.

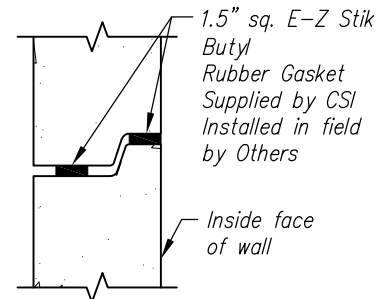

JOINT DETAIL

7,000 GALLON HEAVY DUTY TANK

CONTRACTOR:

Contract No.

ENGINEER:

Date

JOB:

Drawing No.

LOCATION:

HT7K

Revision



Concrete Systems Inc.
 9 Commercial St., Hudson, NH, 03051
 Phone 603-889-4163
 Fax 603-889-0039