

GENERAL NOTES:

1. Concrete Design Strength: $f'c = 4,000$ psi
2. Reinforcing: ASTM A615 (Rebar) Grade 60

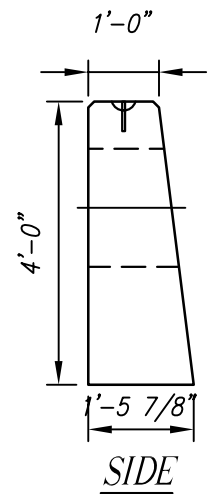
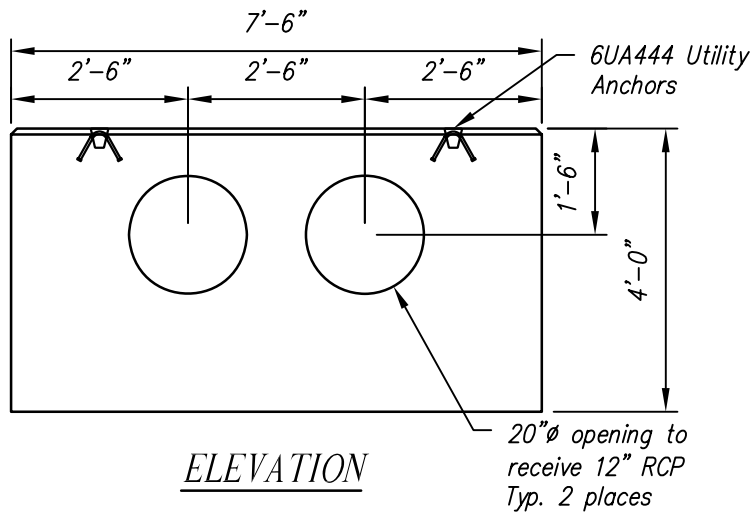
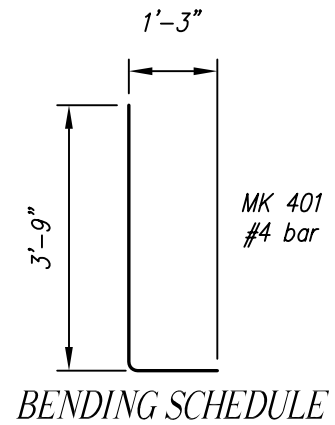
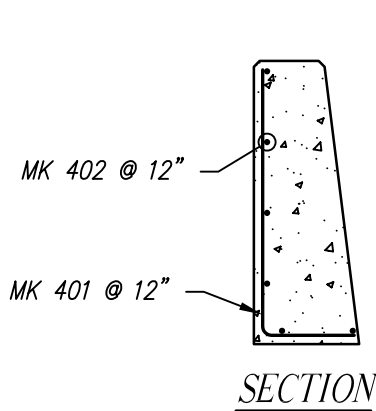

WEIGHT	
BSHW-12DBL	2.40 TONS

BSHW-12DBL - BILL OF MATERIALS / EMBEDS				
CSI ID#	DESCRIPTION	QTY	UM	COMMENTS
EM-00110	UTILITY ANCHOR 6UA444	2	EA	
RM-00013	REBAR #4 BLACK GR 60	60	LB	
MX-FA4000SM	MIX DSGN FLY ASH 4000 SUMMER MIX	1.19	CY	

Rebar Schedule		
MK	QTY	LENGTH
401 #4	8	5' - 0"
402 #4	6	7' - 3"

HEADWALL FOR DUAL 12" RCP
CSI #BSHW-12DBL

CONTRACTOR:

Contract No.

ENGINEER:

Date

JOB:

Drawing No.

LOCATION:

BSHW-12DBL
Revision



Concrete Systems Inc.
9 Commercial St., Hudson, NH, 03051
Phone 603-889-4163
Fax 603-889-0039