

GENERAL NOTES:

1. Concrete Design Strength: $f'c = 4,000$ psi
2. Reinforcing: ASTM A615 (Rebar) Grade 60

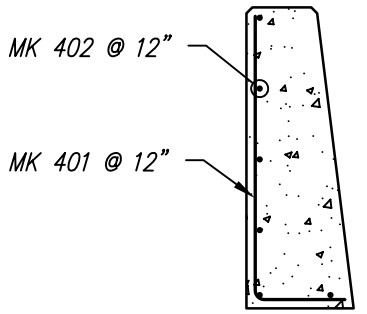

SECTION

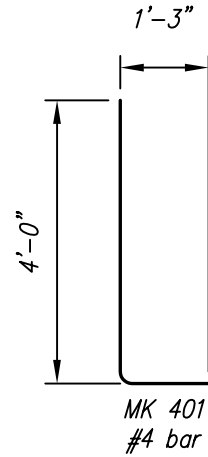

BENDING SCHEDULE

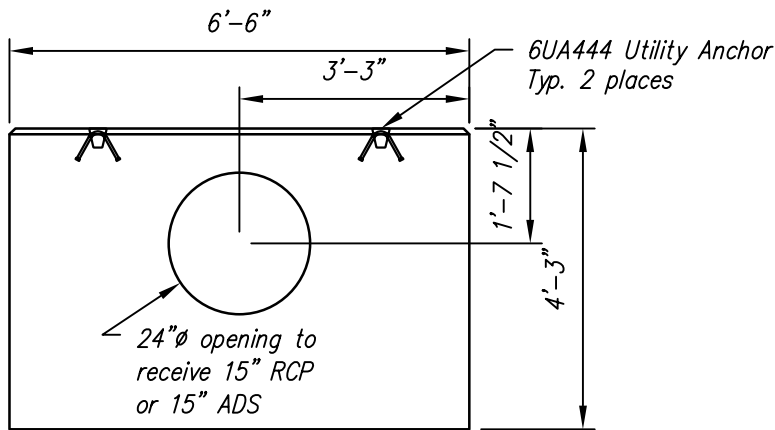

ELEVATION

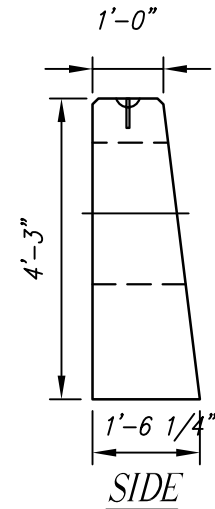

SIDE

WEIGHT	
BSHW-15	2.31 TONS

BSHW-15 - BILL OF MATERIALS / EMBEDS				
CSI ID#	DESCRIPTION	QTY	UM	COMMENTS
EM-00110	UTILITY ANCHOR 6UA444	2	EA	
RM-00013	REBAR #4 BLACK GR 60	50	LB	
MX-FA4000SM	MIX DESIGN FLY ASH 4000 SUMMER MIX	1.14	CY	

Rebar Schedule		
MK	QTY	LENGTH
401 #4	7	5' - 3"
402 #4	6	6' - 3"

HEADWALL FOR 15" RCP OR 15" ADS
CSI #BSHW-15

CONTRACTOR:

Contract No.

ENGINEER:

Date

JOB:

Drawing No.

LOCATION:

BSHW-15
Revision



Concrete Systems Inc.
9 Commercial St., Hudson, NH, 03051
Phone 603-889-4163
Fax 603-889-0039