

**GENERAL NOTES:**

1. Concrete Design Strength:  $f'c = 4,000$  psi
2. Reinforcing: ASTM A615 (Rebar) Grade 60

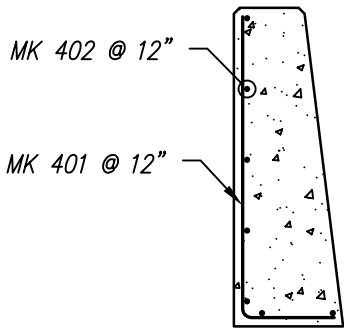

SECTION

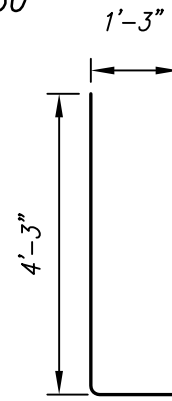

MK 401  
#4 bar  
BENDING SCHEDULE

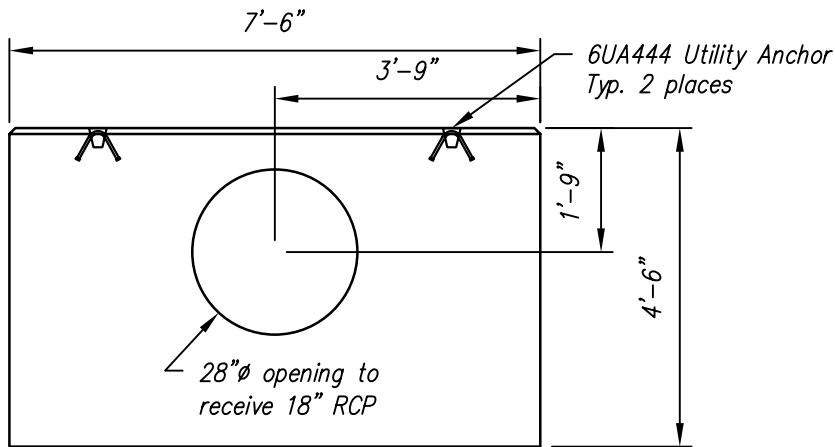

ELEVATION

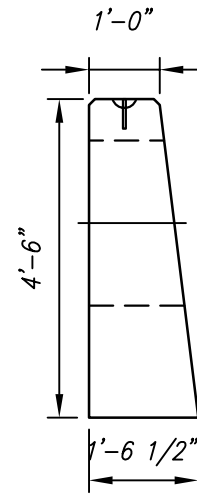

SIDE

WEIGHT	
BSHW-18	2.82 TONS

BSHW-18 - BILL OF MATERIALS / EMBEDS				
CSI ID#	DESCRIPTION	QTY	UM	COMMENTS
EM-00110	UTILITY ANCHOR 6UA444	2	EA	
RM-00013	REBAR #4 BLACK GR 60	63	LB	
MX-FA4000SM	MIX DESIGN FLY ASH 4000 SUMMER MIX	1.39	CY	

Rebar Schedule		
MK	QTY	LENGTH
401 #4	8	5' - 6"
402 #4	7	7' - 3"

HEADWALL FOR 18" RCP  
CSI #BSHW-18

CONTRACTOR:

Contract No.

ENGINEER:

Date

JOB:

Drawing No.

LOCATION:

BSHW-18  
Revision



Concrete Systems Inc.  
9 Commercial St., Hudson, NH, 03051  
Phone 603-889-4163  
Fax 603-889-0039