

**GENERAL NOTES:**

1. Concrete Design Strength:  $f'_c = 4,000$  psi
2. Reinforcing: ASTM A615 (Rebar) Grade 60

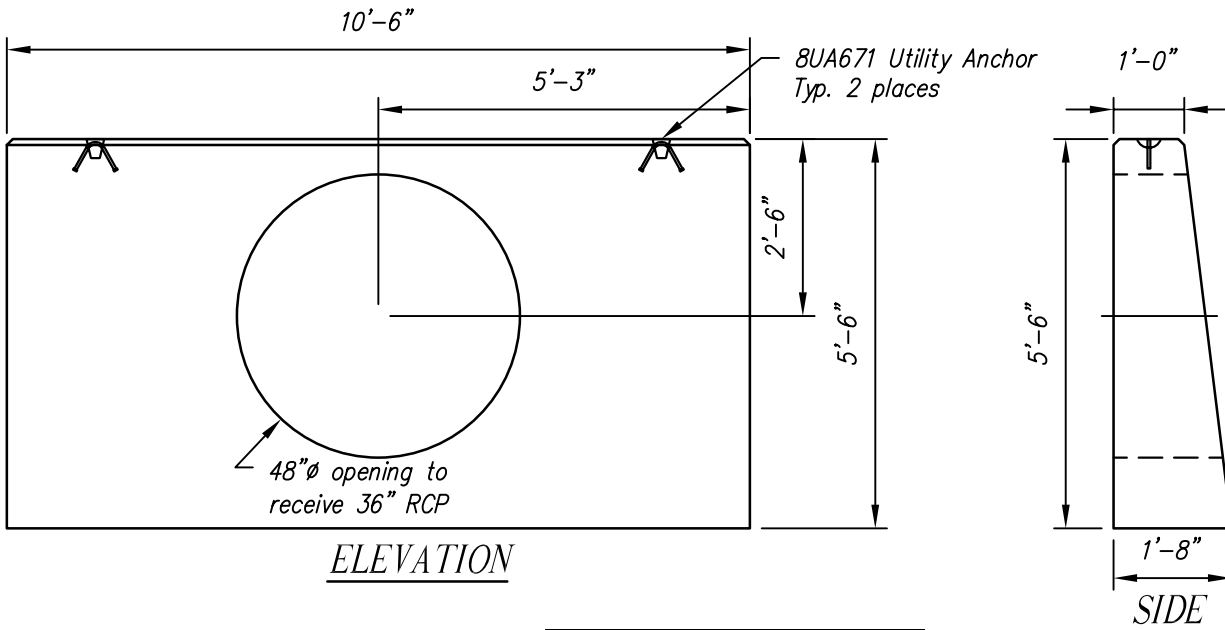
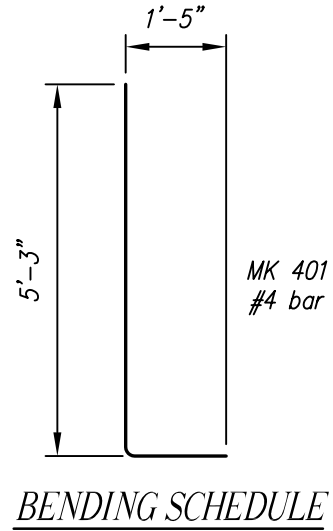
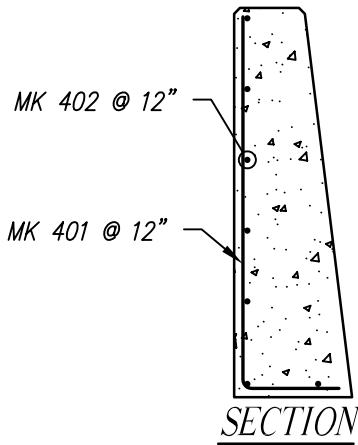

WEIGHT	
BSHW-36	4.53 TONS

BSHW-36 - BILL OF MATERIALS / EMBEDS				
CSI ID#	DESCRIPTION	QTY	UM	COMMENTS
EM-00114	UTILITY ANCHOR 8UA671	2	EA	
RM-00013	REBAR #4 BLACK GR 60	104	LB	
MX-FA4000SM	MIX DESIGN FLY ASH 4000 SUMMER MIX	2.23	CY	

Rebar Schedule		
MK	QTY	LENGTH
401 #4	11	6' - 8"
402 #4	8	10' - 3"

HEADWALL FOR 36" RCP  
CSI #BSHW-36

CONTRACTOR:

Contract No.

ENGINEER:

Date

JOB:

Drawing No.

LOCATION:

BSHW-36

Revision



Concrete Systems Inc.  
9 Commercial St., Hudson, NH, 03051  
Phone 603-889-4163  
Fax 603-889-0039