

GENERAL NOTES:

1. Concrete Design Strength: $f'_c = 4,000$ psi
2. Reinforcing: ASTM A615 (Rebar) Grade 60

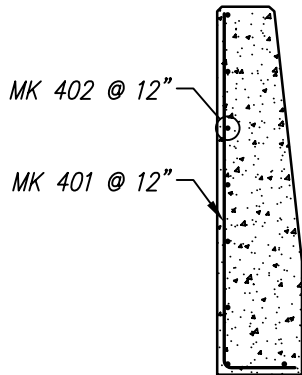

SECTION

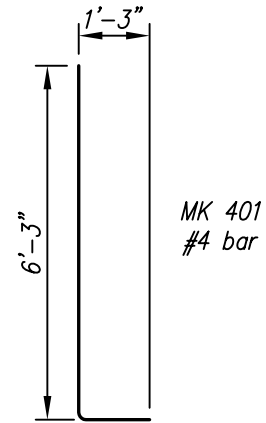

BENDING SCHEDULE

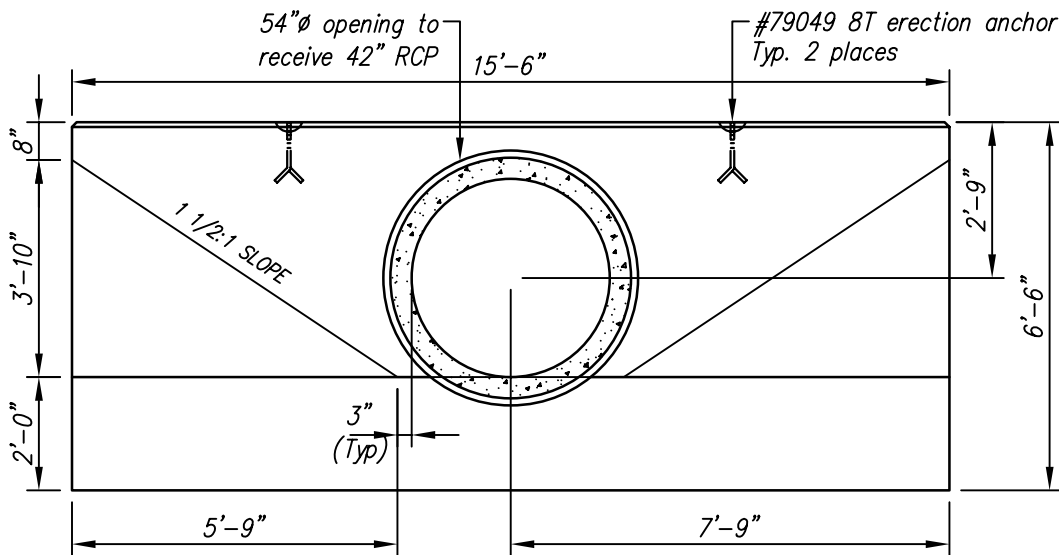

ELEVATION

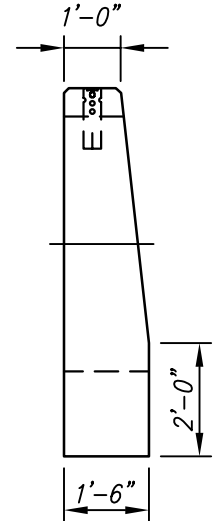

SIDE

BSHW-42 - BILL OF MATERIALS / EMBEDS

CSI ID#	DESCRIPTION	QTY	UM	COMMENTS
EM-00118	8 TON ERECTION ANCHOR #79049	2	EA	
RM-00013	REBAR #4 BLACK GR 60	175	LB	
MX-FA4000SM	MIX DESIGN FLY ASH 4000 SUMMER MIX	4.18	CY	

WEIGHT

BSHW-42	8.46	TONS
---------	------	------

Rebar Schedule

MK	QTY	LENGTH
401 #4	16	7' - 6"
402 #4	9	15' - 3"

HEADWALL FOR 42" RCP
CSI #BSHW-42

CONTRACTOR:

Contract No.

ENGINEER:

Date

JOB:

Drawing No.

LOCATION:

BSHW-42
Revision



Concrete Systems Inc.
9 Commercial St., Hudson, NH, 03051
Phone 603-889-4163
Fax 603-889-0039