

- GENERAL NOTES:**
- Concrete Strength $f_c = 5000$ psi
 - Reinforcing Steel ASTM A615, Grade 60, Galvanized

BILL OF MATERIALS / MEMBERS			
CSI ID#	DESCRIPTION	QTY	UM COMMENTS
EM40032	PVC 2' 20' SCHED 40	2 FT	
RM-00113	TEMP BARRIER GALVANIZED REINFORC	1 EA	
MXFAS0005M	MIX DSGN FLY ASH 5000 SUMMER MIX	1.14 CY	

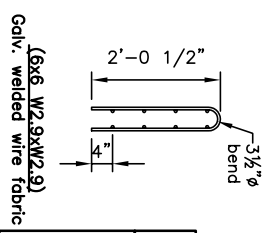
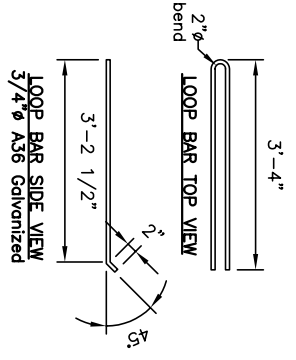
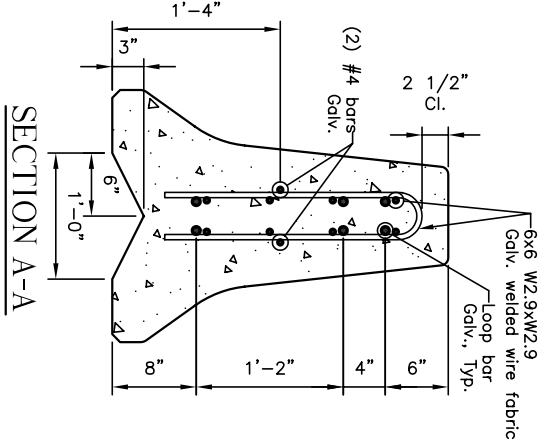

STATE AGENCY
MASS HIGHWAY

Concrete Systems Inc.
9 Commercial St., Hudson, NH 03051
Phone: 603-889-4163
Fax: 603-889-0089

Drawn By	Date
AK	06/11/2003
CONCRETE CUL. TD.	WEIGHT
1.14	2.31 Tons
Approved By	Date

PRECAST PORTABLE CONCRETE BARRIER	
No. Required	Drawing No.
B	DF2432POMA-1
REV	0
SCALE: As Shown	SHEET 1 OF 1